

Footprint

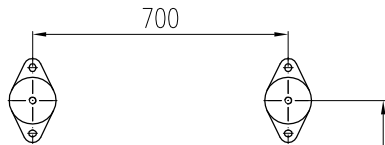

Note:
All dampers can be rotated 360°

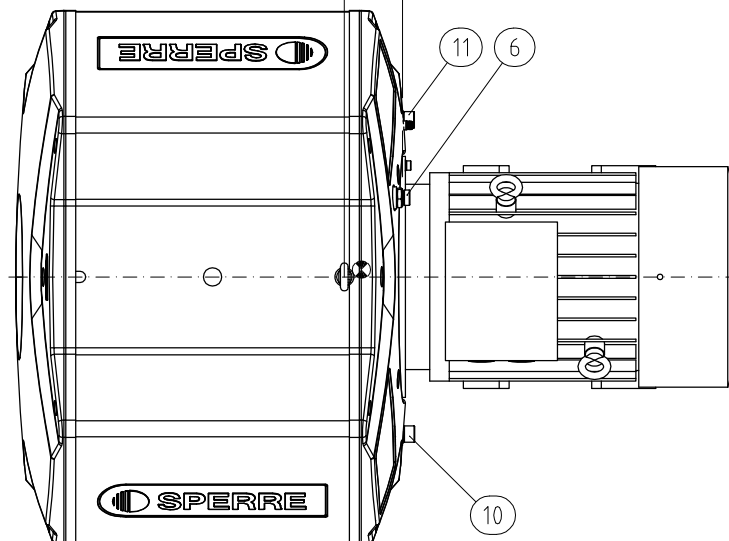
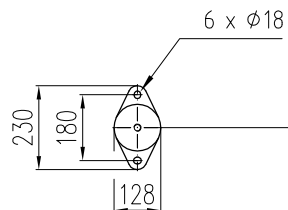

Maintenance space all sides of compressor: Approx. 600 mm

11	1	Cooling water outlet	1 1/4" BSP
10	1	Cooling water inlet	1 1/4" BSP
9	1	Plug & Go connection	
8	1	Cable entry	
7	1	Lifting point	
6	1	Air outlet H.P.	1 1/4" BSP
5	1	Valve, L.P. drain	3/4" BSP w/90 degrees elbow
4	1	Valve, H.P. drain	3/4" BSP w/90 degrees elbow
3	3	Vibration dampers	
2	1	Electrical motor	
1	1	Air Compressor	XW400
Pos	Qty	Description	Remarks

AutoCad Drawn 01.12.09 Approved	Scale: 1:15 Date: RD	Format: A3 Rev. index No. Date	GENERAL ARRANGEMENT Water-Cooled Air Compressor XW400	Former dwg.: New dwg.:	Drawing no. GXW400	Revision
--	-------------------------	-------------------------------------	---	---------------------------	--------------------	----------



This drawing is the property of Sperre Industri AS. It is not to be used, copied or reproduced in any way without the written consent of Sperre Industri AS.